

The MY100e series:
Where high mix meets
high speed.





Faster. Smarter. More responsive. Introducing the MY100e series.

The old days of predictable orders and uniform batch sizes are over. To succeed today you need to manage increasing daily board volumes, last-minute customer demands and disruptive peaks in production. In this environment, new opportunities depend on a solution that's not just faster, but more agile. One that uses smarter material handling and information management to make you more responsive and get more jobs done, day after day.

At MYDATA, we're used to this fast-changing world. As leaders in the high-mix sector, we know that

more flexible solutions simply make business sense. And now, with the MY100e series pick-and-place machines, there's no need to make the usual trade-offs between speed and flexibility. With the fastest changeovers in the industry and workcell solutions reaching speeds of up to 180,000 cph, you can have both. All in one complete solution, with one integrated set of data and one tracking system for all components. Because the race to get ahead is no longer about machine cycle time. It's about responding to your customers' needs with the fastest, most agile solution on the market. Period.

Four models. Two sizes. A total solution for every need.



MY100HXe-10/14
High-speed chip and low-profile IC mounter. Featuring up to 160 feeder positions with a top speed of 50,000 components per hour.



MY100DXe-10/14
High-speed all-in-one mounter. Featuring up to 160 feeder positions with a top speed of 40,000 components per hour.



MY100SXe-10/14
Flexible all-in-one mounter. Featuring up to 176 feeder positions with a top speed of 24,000 components per hour.



MY100LXe-10/14
All-in-one mounter. Featuring up to 176 feeder positions with a top speed of 16,000 components per hour.

Years ago, the MY100 changed the way we think of high-mix SMT production. The most versatile and upgradeable pick-and-place machines on the market, it proved that any manufacturer – from the start-up, to the prototyper, to the 24/7 factory – can become more flexible and more productive with the help of a single platform.

Now, with the MY100e series, the flexibility MYDATA is known for just got faster. With production workcells reaching speeds of up to 180,000 cph, and with four models to choose from, you can now serve more types of customers with better responsiveness than ever before.

New to the lineup is the MY100HXe, our fastest model to date and a welcome addition for high- and mid-volume manufacturers. It is capable of outputs as

high as 50,000 cph, allowing you to configure lines and workcells that mount a vast mix of component types more than 30 percent faster than with previous models.

And now, with the MY100DXe, MY100SXe and MY100LXe, you can get more boards off your line per day, no matter which configuration you choose. Always with faster changeovers, easy upgrades and intelligent material handling. Always to keep you ahead of the competition.

Board handling for any facility

MYDATA's board handling solutions allow you to produce a wide range of boards for an even wider array of customers. From the smallest boards to the heaviest, and even odd-shaped boards in-line, each piece of equipment offers complete integration with your production process.

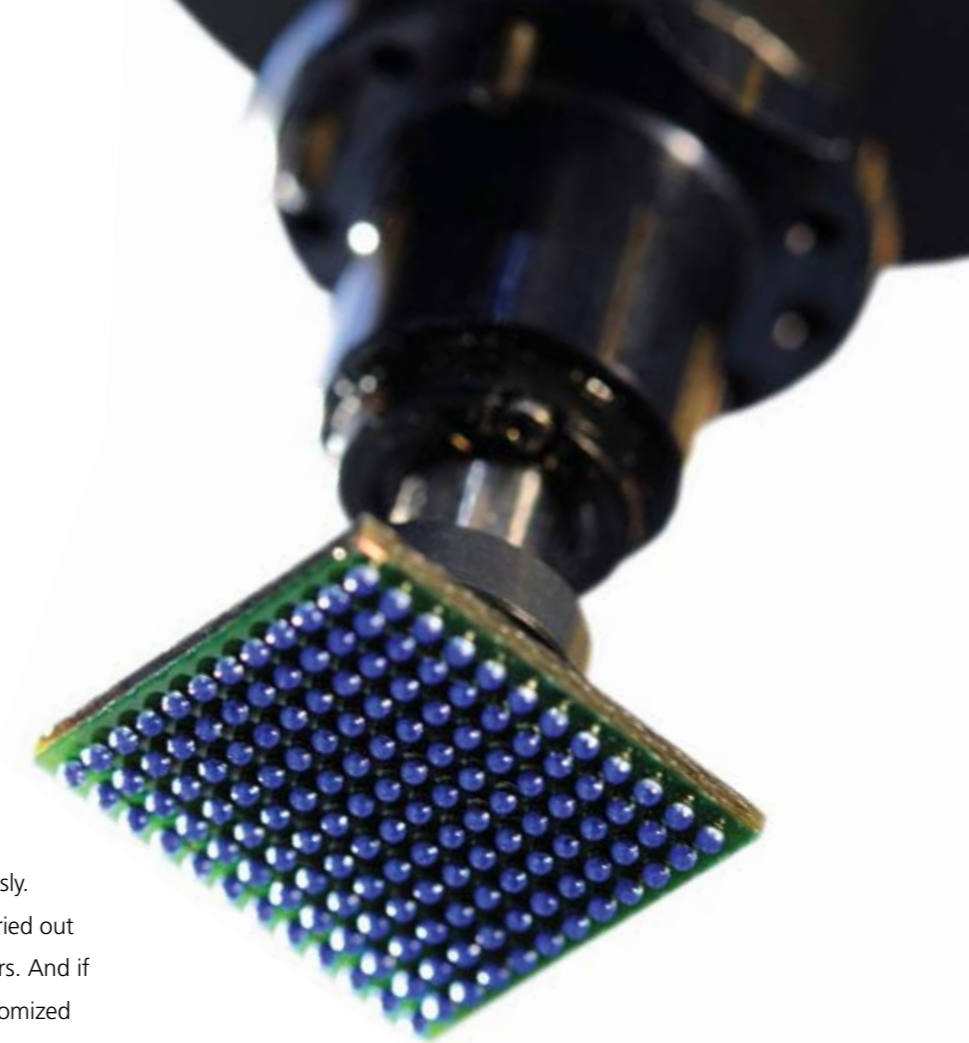

Board train functionality can also significantly increase throughput by allowing loading and unloading of multiple boards simultaneously. Switching to a manual load system can be carried out in seconds using optional manual load adaptors. And if these options still don't meet your needs, customized solutions can be developed to suit your particular boards.

Accuracy is everything

MYDATA machines have long been leaders in accuracy. And the MY100e series is no exception. Rigid machine frames, precise mounthead technology and Automatic Thermal Adaption ensure excellent accuracy under all operating conditions, and for all components. And because each machine can be upgraded and optimized as needed, you'll always be prepared for any new package technologies that might arise in the future.

Advanced vision systems

Thanks to advanced vision system technology, on-the-fly centering and precise placement of miniaturized and specialized components has never been more reliable. The Linescan Vision System (LVS) combines maximum centering speed and highest precision for the vast majority of components, whereas the Dual Vision System (DVS) takes care of flip chips and other specialized components.

High-speed, high-precision mountheads

Large, fine-pitch components. QFPs, BGAs, flip chips or the smallest chip components. MYDATA offers the full range of flexibility for all components and all batch sizes, whether it's due to the robust precision of our standard Midas mountheads, or the high-speed, eight-nozzle HYDRA mounthead. Accurate as always. Now faster than ever.

Eliminate errors. Reduce rework.

Why risk incorrectly loaded components? With on-the-fly electrical verification, you don't have to. The process, which takes place during centering, is 100 percent effective at verifying the value of transistors, resistors, capacitors, diodes, and the orientation of active, polarized components. Incorrect components are automatically rejected while the machine continues building the board, thus guaranteeing quality while eliminating time-consuming rework.

Smarter software means better business

At the heart of any MYDATA solution is the richest software street in the industry. Intuitive, easy to use and simple to integrate with nearly any ERP system, it puts you fully in control of the most agile production platform available. All to help you increase utilization, boost efficiency, improve customer service and impact your bottom-line.

The MYDATA software suite includes:

- Full visibility planning for converting CAD and material data without error
- Unmatched stock accuracy with scannable feeders and faster changeovers
- Complete traceability down to individual PCB level
- Advanced line automation linking barcodes to product orders for improved utilization
- Performance monitoring with an intelligent, real-time web interface



The Agilis feeder system

– material management made easy

MYDATA's modular feeder system is designed for accuracy, ease of use and convenience. It gains unrivalled flexibility from a combination of intelligent feeders and magazines for tapes and sticks. Our unique Agilis feeders with no moving parts are easier and quicker to load than any other on the market. And by keeping preloaded Agilis feeders on hand, you can perform set-ups and changeovers even faster. Since all MYDATA magazines can be replenished while the machine is running, you never have to stop production if you run out of components.

In addition, all magazines and Agilis feeders have a unique identity that links them to the machine's system software. This enables the machine to recognize the presence, absence and location of components – a

valuable asset when it comes to keeping track of inventory, since the machine knows exactly how many components are left on each tape reel. In addition, pick positions never have to be reprogrammed. Instead, the system software recognizes the feeder instantly, regardless of machine or position, and re-optimizes the mounting program to maintain highest efficiency.

More feeders. More output. Less space.

Thanks to the machines' compact design, up to 176 intelligent feeders can be accommodated within a surprisingly small footprint. The design also allows a larger board size capacity, which not only allows you to handle more variations in board design but also leads to significantly increased throughput using the board train function.



High capacity and high mix – without compromise

Combine two MY100HXe/MY100DXe lines in a single workcell, and you have a full 180,000 cph placement capacity at your control. For continuous high-speed production this means a proactive, fully automated material flow, run by fewer operators. Better yet, MYDATA makes it easy to transition from high volume to small test batches or prototypes. No re-programming, no re-tooling and no reconfiguring of vision camera parameters. Simply a seamless workflow from NPI to volume production.

With just a single operator, you can maintain continuous production under all circumstances. Even when building prototypes, you'll have a minimal impact on overall efficiency. And with all of this in a single vendor, it's also possible to reduce training and maintenance costs while allowing for higher degrees of freedom in staffing and planning decisions.

Key benefits

- 180,000 cph within one workcell
- On-the-fly changeovers
- Near-production storage and automated replenishment
- Electrical verification of resistors, capacitors, diodes and transistors
- Full traceability

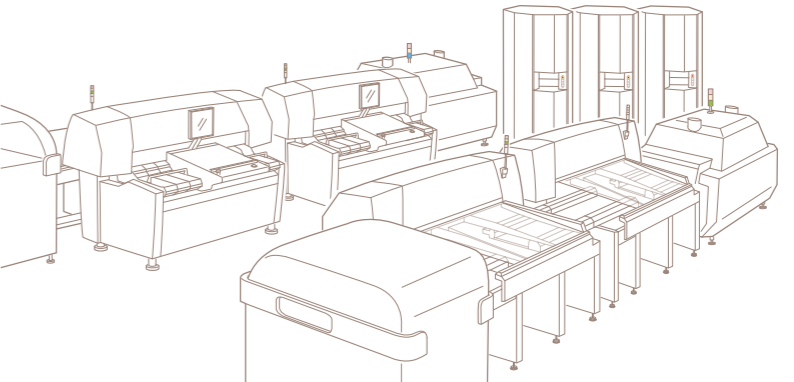

High capacity workcell. Two MY100HXe and DXe lines including the SMD Tower for automated near-buffer storage.



MY100HXe-10/14
High-speed chip and low-profile IC mounter. Featuring up to 160 feeder positions with a top speed of 50,000 components per hour.

Introducing the MY100HXe – a breakthrough in agility

With a dual X drive system that combines high-speed, high-precision mounthead with advanced vision systems and state-of-the-art linear drive motor technology, the new MY100HXe reaches top speeds of up to 50,000 components per hour. The model's 18 nozzles ensure excellent throughput for chip components and low-profile BGAs and QFPs.

SMD Tower – automated near-production storage

The SMD Tower is a highly flexible, automated and expandable buffer storage unit. Designed for near-production deployment, it ensures that the right components remain stored in the correct place and in a controlled atmosphere, always ready for a quick and smooth line changeovers. With just one square meter of floorspace, it can store up to 546 reels while recording all movements and quantities.

The high-mix workhorse

For those who demand versatility, two MY100DXe machines arranged in a single line form an agile, modular production unit capable of meeting any future needs. Whichever configuration you choose, you'll be able to reduce production costs and delivery times thanks to high speeds, high feeder counts and full visibility planning. And because all equipment is based on a single platform and source, software packages can be added as needed, always ensuring full traceability down to PCB ID level.

Technology that stands the tests of time
MYDATA offers a range of value-added packages specially tailored to the demands of subcontractors. This includes a fully future-proof solution combining software with services such as operator training courses, production and process support as well as process and knowledge courses. With the right training and the right equipment, your investments will pay off for years to come.



MY100DXe-10/14

High-speed all-in-one mounter. Featuring up to 160 feeder positions with a top speed of 40,000 components per hour. Upgradeable to MY100HXe.

MY100DXe – now faster than ever

With a dual X drive system that combines high-speed and high-precision mounthead, advanced vision systems and a state-of-the-art linear drive motor technology, the MY100DXe now reaches top speeds of up to 40,000 components per hour. With 18 nozzles in total, you will be capable of mounting a vast mix of component types, resulting in excellent throughput.

Of course, your production needs will change as your business expands. This is no problem for the MY100DXe, which can easily be reconfigured to a high-

speed MY100HXe. This means that your investment grows along with your business, without any of the additional purchases, production changes or retraining that the purchase of a new machine would otherwise require.

Speed up your set-ups

A new package definition can be created in seconds using the AutoTeach function. Just show the unknown package to the vision system, and all geometrical data is measured automatically – saving you a significant amount of time when setting up new jobs.

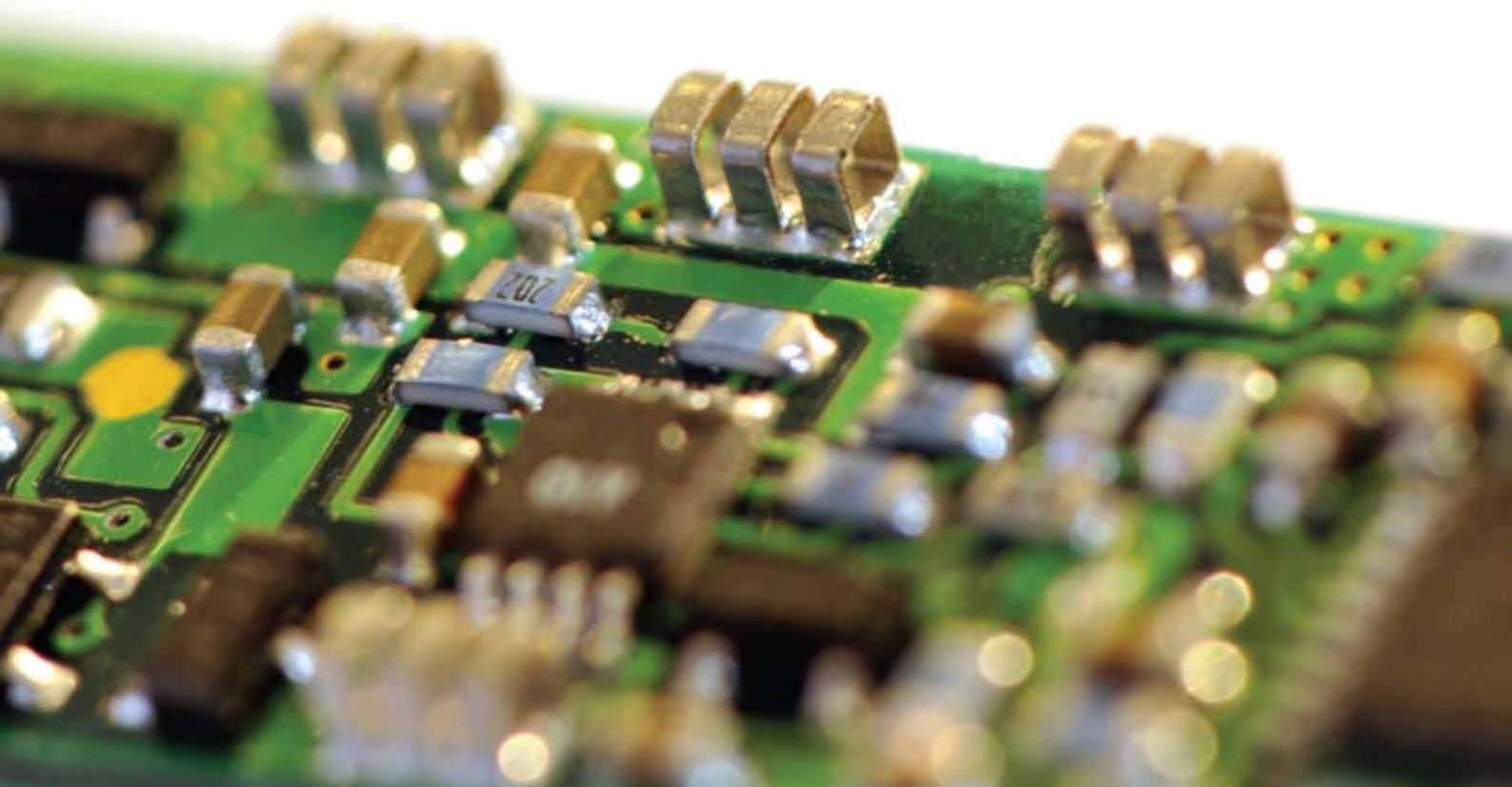

Key benefits

- 80,000 cph with up to 320 feeder positions
- Modular design – allowing easy reconfigurations between DXe and HXe models
- A complete SMT assembly solution from a single source
- Fastest changeovers in the industry
- Full traceability

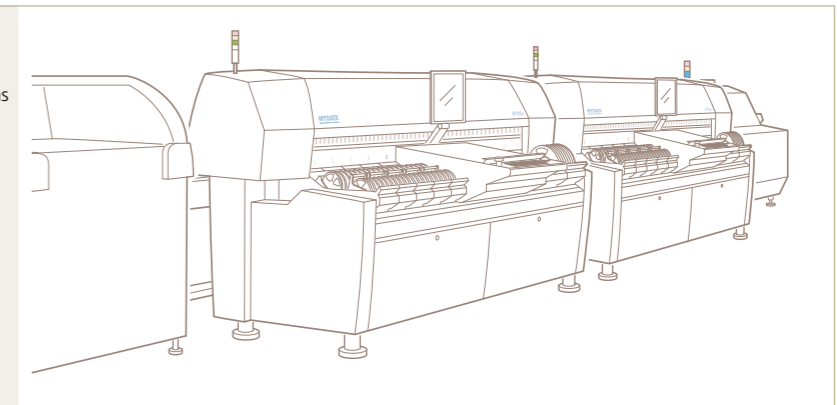

Flexible high-capacity line. MY100DXe-14 Synergy line rated at 80,000 cph with 320 feeder positions.

Fully automated short series production

As batch sizes decrease, uptime doesn't have to suffer. By combining software-driven solder paste application with high feeder capacity and the unique FlowLine concept, continuous operation is both easy and economical – down to small batch sizes, or even a single board.

Automation down to the smallest detail
MYDATA's planning software makes it possible to analyze hundreds of work orders and organize them into family kits, perfectly sized to ensure hours of non-stop production. With the help of proactive replenishment notifica-

tions, you'll finally be able to close the efficiency gap between high-volume and short-series production.

Build products, not inventory
With changeovers this easy, any job is possible. Batch sizes can be optimized for downstream operations including inspection, testing and box build. And instead of building stock inventory, you can build-to-order, thereby reducing risk and working capital while removing the risk of old-revision products.



MY100SXe-10/14
Flexible all-in-one mounter. Featuring up to 176 feeder positions with a top speed of 24,000 components per hour.

MY100SXe – the future of flexibility

At up to 24,000 cph, the MY100SXe gives you the flexibility you need to tackle tomorrow's challenges. It is ideal for high-mix production, handling up to 176 feeders and an endless variety of components. Advanced mounthead, state-of-the-art vision systems and a broad variety of conveyor widths all ensure that the line is able to accommodate a range of board sizes, shapes and technologies. Based on the same technology platform as the MY100DXe, the MY100SXe features a single mount-

head carrier that picks components from both sides of the machine. This provides incredible flexibility while maintaining the ability for on-the-go setups and seamless changeovers from one production run to another. The high-precision linear drive and distributed servo technology provide the ability to increase throughput, while continuous accuracy calibration maintains the high level of quality that you would expect from a MYDATA machine.

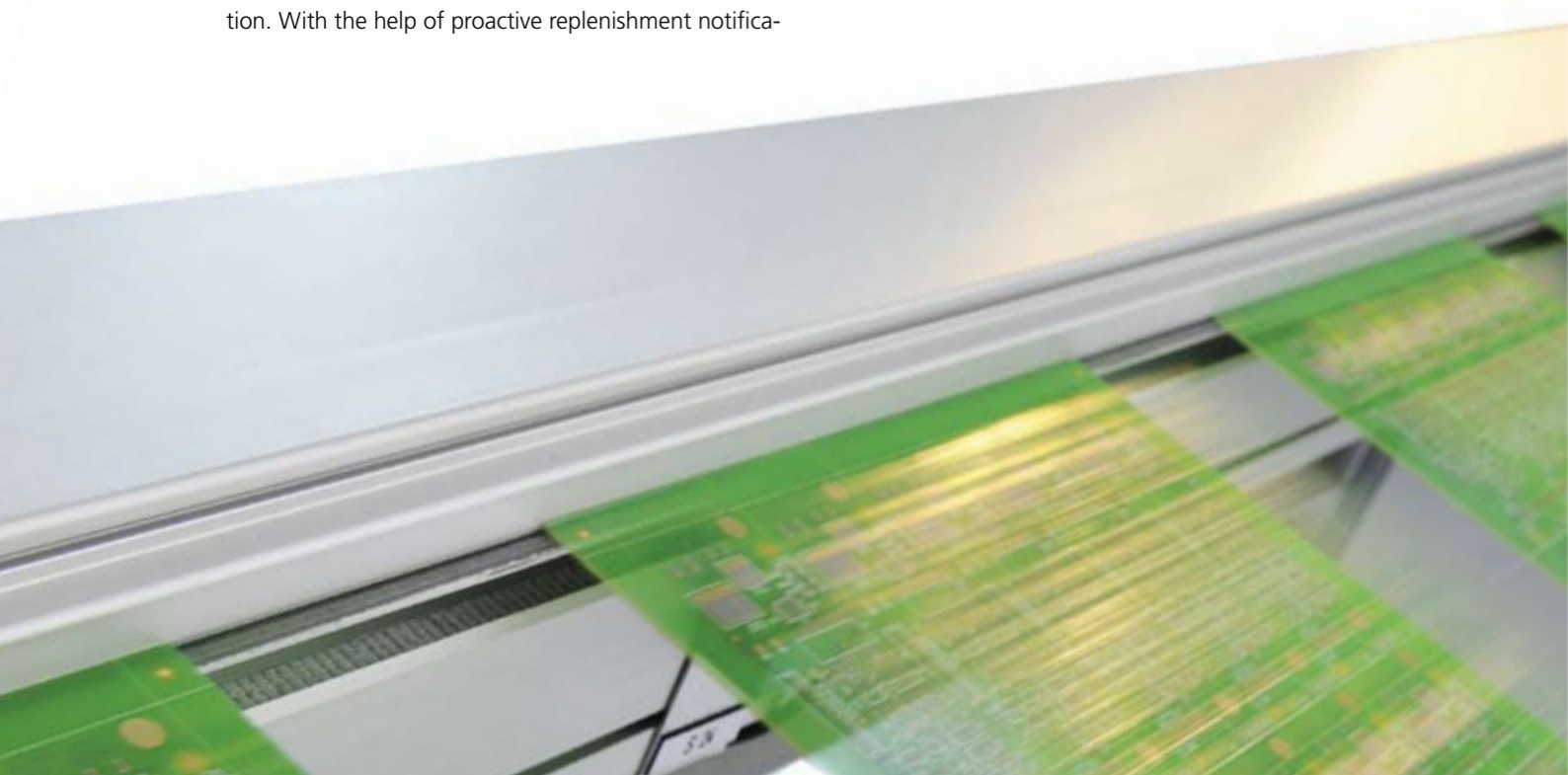

Key benefits

- Zero changeover time with no operator intervention
- Stencil-free, software-driven printing
- Feeder capacity enough for family kitting and on-the-fly changeovers
- On-the-fly verification of resistors, capacitors, diodes and transistors

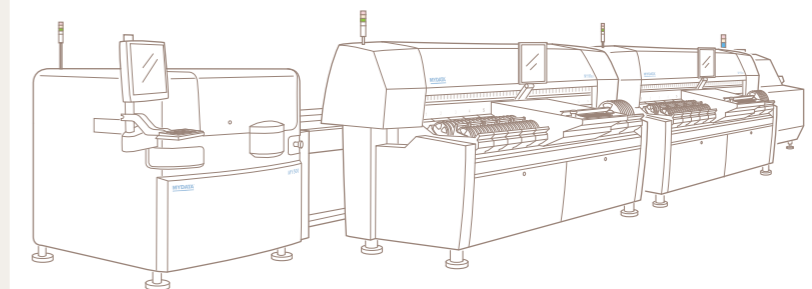

Automated short series production. MY500 in-line with a MY100SXe-14 Synergy line.

The all-in-one solution

Combine a MY500 Jet Printer with a MY100SXe or MY100LXe pick-and-place machine, and you'll never have to say no to another customer. Instead, you'll be able to handle any package or PCB and place it on nearly any surface – for the entire lifespan of your machines. Although technologies may change, as a start-up contract manufacturer you'll always be able to adapt.

Handle any order – today and tomorrow
Whether your components arrive in short tape strips, matrix trays with oversized pockets or just a plastic bag, the flexible system software of the MY100e turns nearly anything into a component feeder. And with the stencil-free printing of the MY500, even last-second customer changes can be done on the spot, whenever necessary. Whatever quantity, whatever technology and whatever size component, this is a pair of machines that grows with your business.



MY500
Jet Printing technology for stencil-free application of solder paste or SMA.

MY100LXe-10/14
All-in-one mounter. Featuring up to 176 feeder positions with a top speed of 16,000 components per hour. Upgradeable to MY100SXe.

MY500 – the ultimate in agility

The MY500 is completely software driven, applying solder paste or SMA onto complex boards with high precision. QFNs, pin-in-paste, package-on-package or other applications that have yet to be invented – all of these techniques can be carried out with unmatched precision and flexibility

Without the limits posed by stencils, you'll never have to compromise on solder joint quality. Instead of days, you can prepare jobs in minutes. If you do 2-3 setups a day, using more than 50 stencils a year, you'll quickly realize the benefits. If you also have customers calling for last-minute changes, you'll understand even better.

Key benefits

- Full component range in one machine
- Fastest set-ups and changeovers in the industry
- Capable of pin-in-paste, PoP, QFN, board cavities and more
- Stencil-free printing
- On-the-spot board revisions
- Handle short tape strips and non-standard carriers

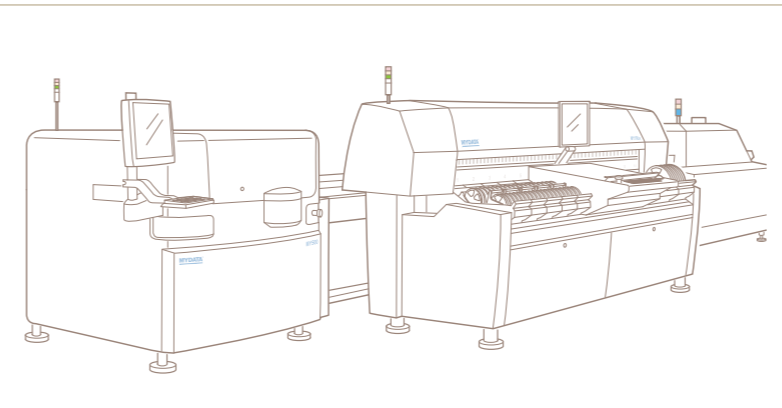

All-in-one solution. MY500 in-line with a MY100SXe/LXe.

For more than 20 years, MYDATA's innovations have changed the face of the high-mix SMT industry – from stencil-free jet printers and on-the-fly electrical verifiers, to fast-loading intelligent feeder systems and advanced software solutions.

All one-of-a-kind technologies. And all with one goal in mind: to simplify and streamline an increasingly complex production environment with a single integrated platform.

Today, our global network and around-the-clock service organizations continue to fulfill this mission, providing upgrades, support and optimization to customers around the world. Because with MYDATA, you're never just buying a machine. You're investing in the market's most complete, flexible solution for high-mix production. One that adapts to meet your needs, to solve future challenges – before they arrive.

MYDATA – Accelerate your success

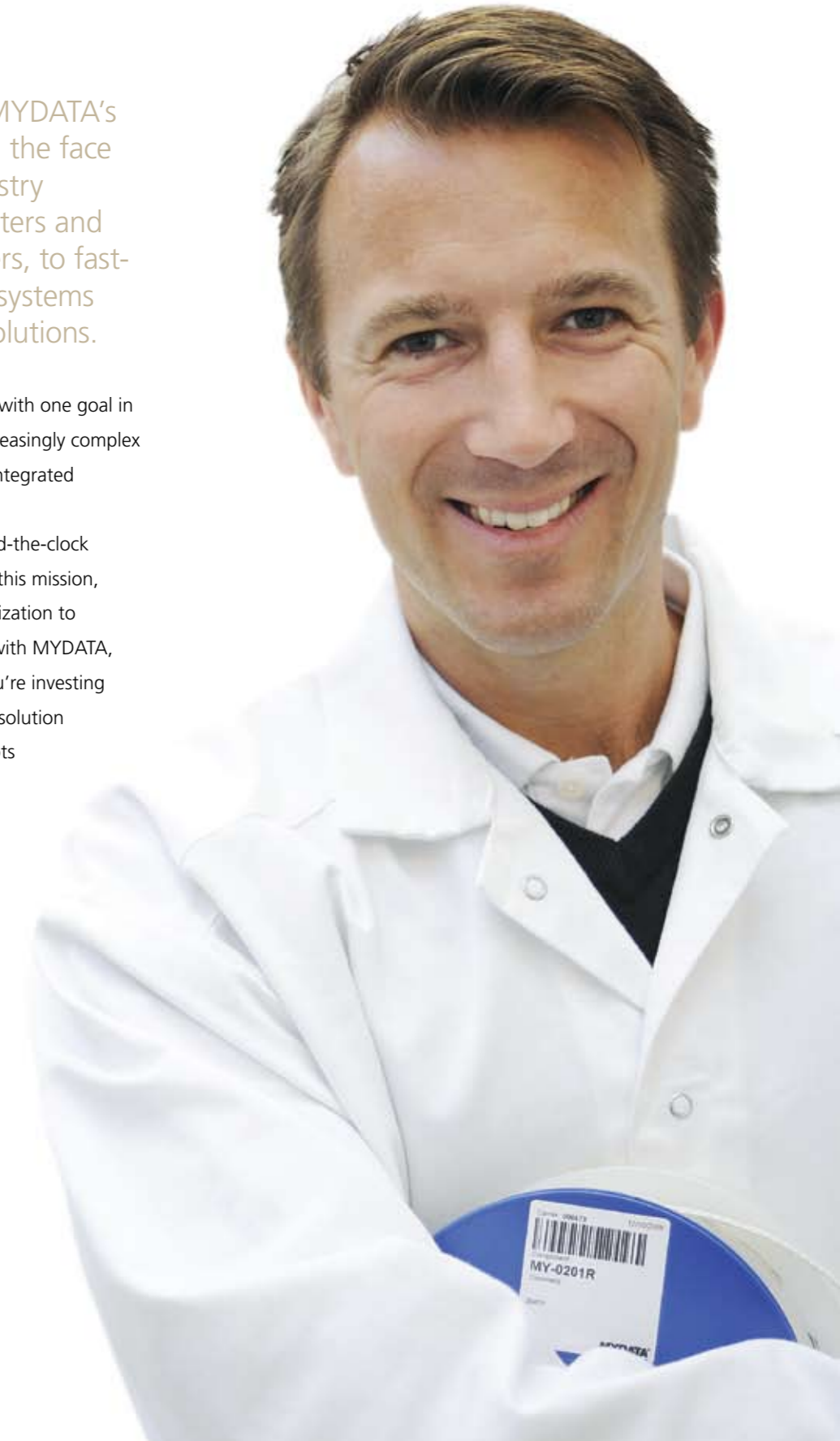



SWEDEN

Micronic Mydata AB
 PO Box 3141
 Nytorpsvägen 9
 SE-183 03 Täby
 Sweden
 Tel: +46 8 638 52 00
 Fax: +46 8 638 52 90

JAPAN

Micronic Mydata Japan K.K.
 Mitsugi-Kotobukicho Bldg.
 1-1-3 Kotobuki-cho, Fuchu-shi
 Tokyo 183-0056
 Japan
 Tel: +81 42 354 1320
 Fax: +81 42 354 1321

CHINA

Micronic Mydata (Shanghai) Co., Ltd.
 Unit 101, K Block
 Lane 168, Da Duhe Road
 Putuo District, 200062
 Shanghai
 Tel: +86 21 3252 3785/86
 Fax: +86 21 3252 3780

SINGAPORE

MYDATA Asia Pte Ltd.
 5, Pereira Road, #01-01
 Asiawide Industrial Building
 Singapore 368 025
 Tel: +65 6281 7997
 Fax: +65 6281 7667

USA

MYDATA automation, Inc.
 320 Newburyport Turnpike
 Rowley MA 01969-2002
 USA
 Tel: +1 978 948 6919
 Fax: +1 978 948 6915

UK

MYDATA automation Ltd.
 Unit 2, Concept Park
 Innovation Close
 Poole, Dorset, BH12 4QT
 United Kingdom
 Tel: +44 1202 723 585
 Fax: +44 1202 723 269

BENELUX

MYDATA automation B.V.
 Eindhoven Airport
 Flightforum 880
 5657 DV, Netherlands
 Tel: +31 402 62 06 67
 Fax: +31 402 62 06 68

FRANCE

MYDATA automation S.A.
 13 Rue de Norvège BP122
 91944 Courtaboeuf Cedex
 France
 Tel: +33 1 69 59 24 34
 Fax: +33 1 69 28 71 00

GERMANY

MYDATA Royonic GmbH
 Wächterhofstraße 50
 85635 Höhenkirchen
 Germany
 Tel: +49 8102 749090
 Fax: +49 8102 749098



www.mydata.com
info@mydata.se

MYDATA, MYDATA automation and MY, MY100, MY100DX, MY100SX, MY100LX, MY100e, MY100HXe, MY100DXe, MY100SXe, MY100LXe, MY500 and MYSynergy, T3, T4, T5 and T6, HYDRA Speedmount, Midas, ISC, Agilis, Agilis Linear Magazine (ALM), Agilis Stick Magazine (ASM), MYDATA Tray Exchanger (TEX), MYDATA Tape Magazine (TM), MYDATA Tray Wagon Magazine (TWM), MYDATA Dip Unit (DPU), MYDATA Standard Vision System (SVS), MYDATA Dual Vision System (DVS), MYDATA Linescan Vision System (LVS), MYDATA HYDRA Vision System (HVS), MYDATA Assembly Process Management (APM) including: iPSys, TP5ys, MYLabel, MYPlan, MYTrace, MYCam, Flowline and CAD Conversion are registered trademarks or trademarks of MYDATA automation AB. MYDATA is ISO 9001:2008 certified.